



IOCHPE-MAXION 25
INVESTOR
DAY 2



AGENDA

- Boas-vindas e introdução
- Iochpe-Maxion
- Maxion Structural Components
- Maxion Wheels
- Encerramento e Q&A

APRESENTADORES DE HOJE

Renato Salum

CFO e DRI
Iochpe-Maxion

Pieter Klinkers

Presidente e CEO
Iochpe-Maxion

Rodrigo Caraça

Gerente Sênior
de RI
Iochpe-Maxion

Mark Gerardts

CEO
Maxion Wheels

Renato Brighenti

CEO
Maxion Structural
Components

PIETER KLINKERS
PRESIDENTE E CEO
IOCHPE-MAXION



SOBRE
IOCHPE-
MAXION

Maior fornecedor global de rodas do mundo, com aproximadamente **50 milhões** de rodas produzidas anualmente

Fornecedor líder de componentes estruturais automotivos nas Américas



Manisa, Turquia



Castaños, México

33 Plantas
14 países

Mais de 17.000
funcionários

Diversos produtos novos, inovadores e competitivos em termos de custo, em todas as regiões: experiência global aplicada localmente



OPERANDO DOIS NEGÓCIOS: EXPLORANDO MAIS SINERGIAS



Produção de rodas para veículos leves e comerciais, agrícola, defesa, transporte de materiais e aplicações *off-road*

Aprox. **78%**
da receita líquida



Mais sinergias em processos essenciais, como inovação, desenvolvimento de produtos, comercialização, cadeia de suprimentos, sustentabilidade, recursos humanos, IA/Transformação Digital



Produção de componentes estruturais para veículos comerciais e leves

Aprox. **22%**
da receita líquida

ENTREGANDO VALOR: EM TODO O MUNDO



- MAXION WHEELS
- MAXION WHEELS EM CRESCIMENTO
- MAXION STRUCTURAL COMPONENTS
- MAXION STRUCTURAL COMPONENTS EM CRESCIMENTO



TRANSFORMANDO A DINÂMICA EM VALOR PARA OS ACIONISTAS

- Presença estratégica global com foco no mercado regional
- Portfólio completo e inovador de produtos
- Foco contínuo no valor para os acionistas
 - Execução da eficiência operacional
 - Superando o mercado
 - Potencial para crescimento inteligente, com a infraestrutura existente

RENATO SALUM

CFO e DRI
IOCHPE-MAXION



AGENDA

- Produção global de veículos
- Desempenho financeiro
- Resultados financeiros do 2T25
- Manutenção da disciplina financeira

MERCADO: PRODUÇÃO GLOBAL DE VEÍCULOS

Veículos leves¹
(Unidade em milhões)

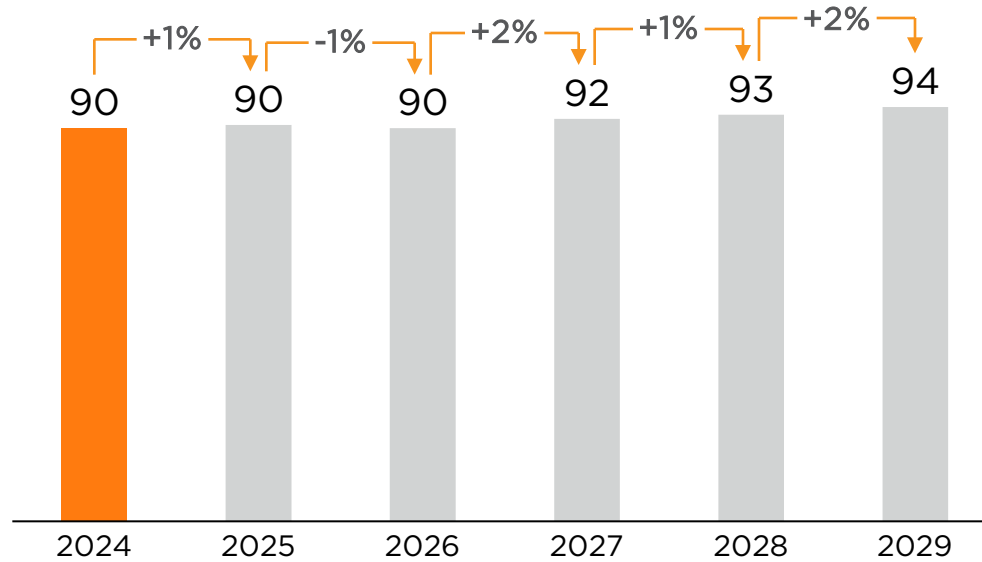

Produção global excluindo a China - var.

-1% -1% +3% +2% +3%

Veículos comerciais²
(Unidade em milhares)

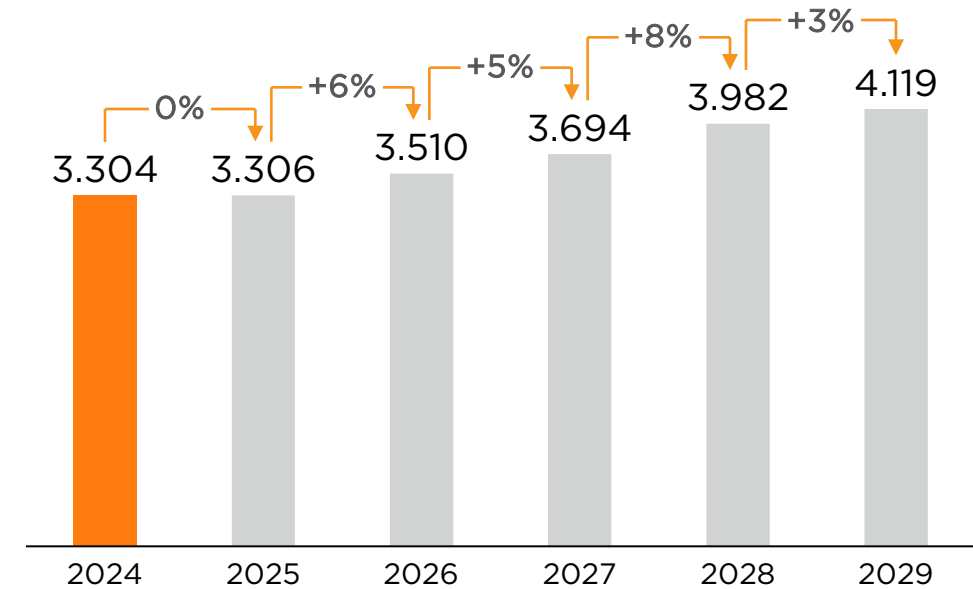

-5% +7% +4% +8% +2%

DESTAQUES FINANCEIROS: DESEMPENHO CONSISTENTE

2T25



Receita líquida

R\$ 4,1 bilhões



Lucro bruto

R\$ 535 milhões
com margem
bruta de 13,0%



EBITDA

R\$ 450 milhões
com margem de
11,0%



Lucro líquido

R\$ 87 milhões,
com margem de
2,1%



Alavancagem

Dívida
líquida/EBITDA
de 2,38x

1S25



Receita líquida

R\$ 8,0 bilhões



Lucro Bruto

R\$ 978 milhões
com margem
bruta de 12,2%



EBITDA

R\$ 805 milhões
com margem de
10,0%



Lucro líquido

R\$ 98 milhões,
com margem de
1,2%

RECEITA LÍQUIDA: MANUTENÇÃO DO RITMO DE CRESCIMENTO

1S25

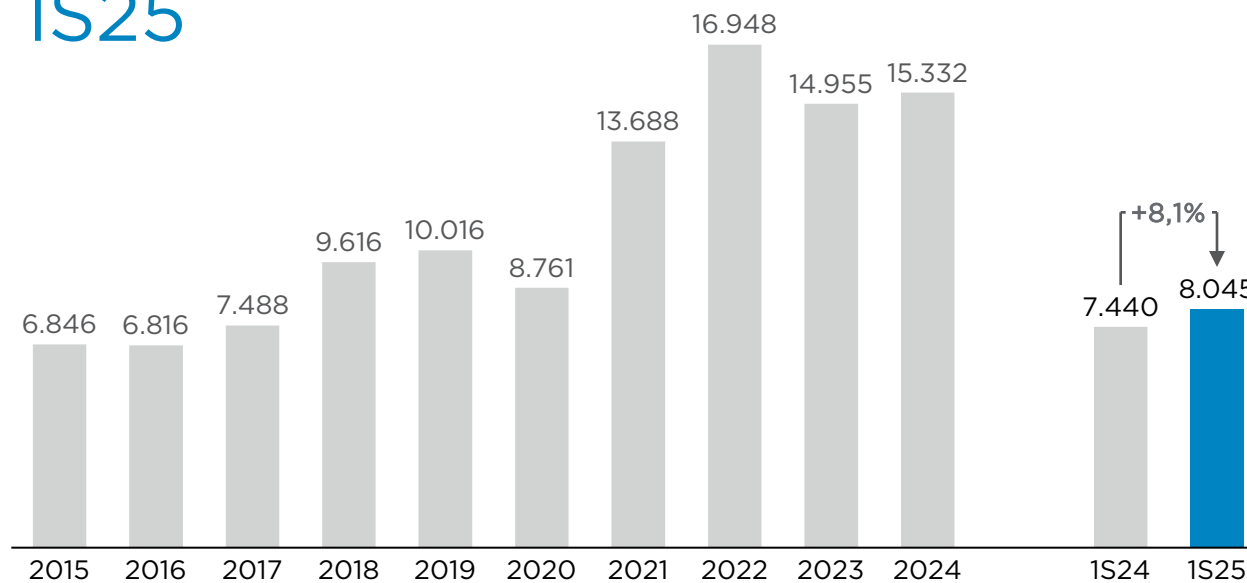

Receita por região (%)

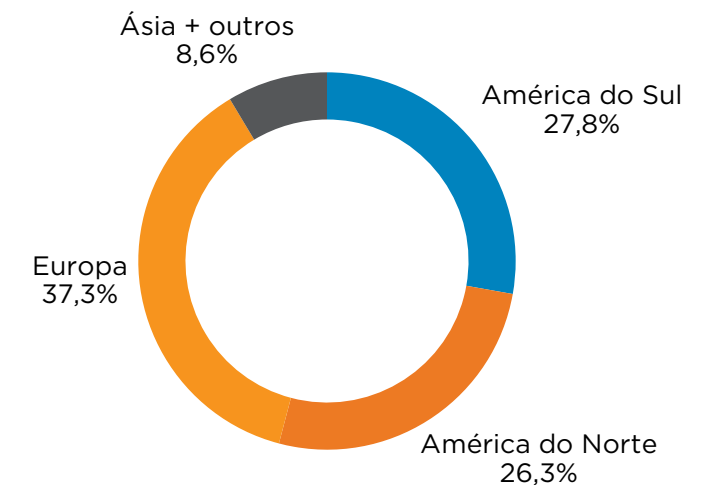

RECEITA 2T25: POR PRODUTO

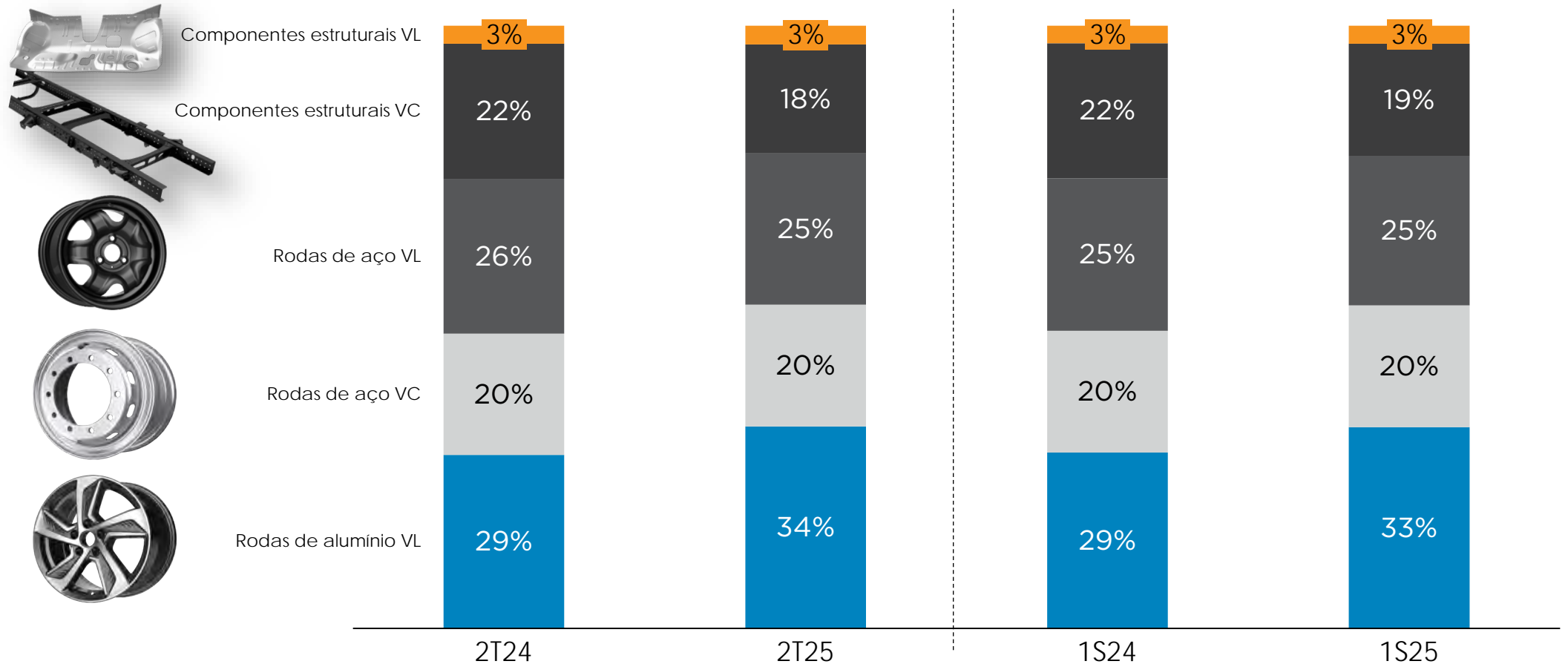

VL: veículos leves
VC: veículos comerciais

RECEITA 2T25: POR CLIENTE

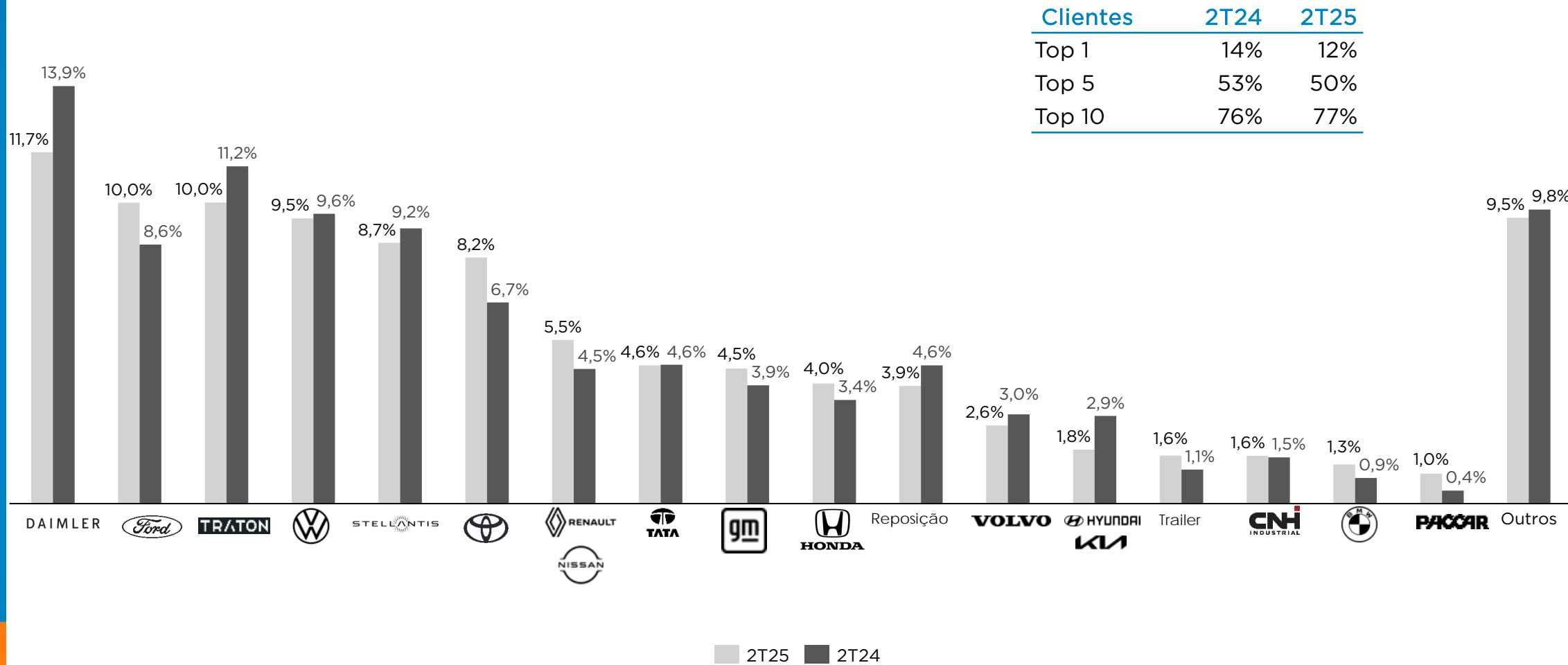

EBITDA E MARGEM EBITDA (%): IMPULSIONANDO A RENTABILIDADE COM DISCIPLINA

Crescimento de 0,9 p.p. na margem EBITDA no 2T25 e de 0,5 p.p. no 1S25

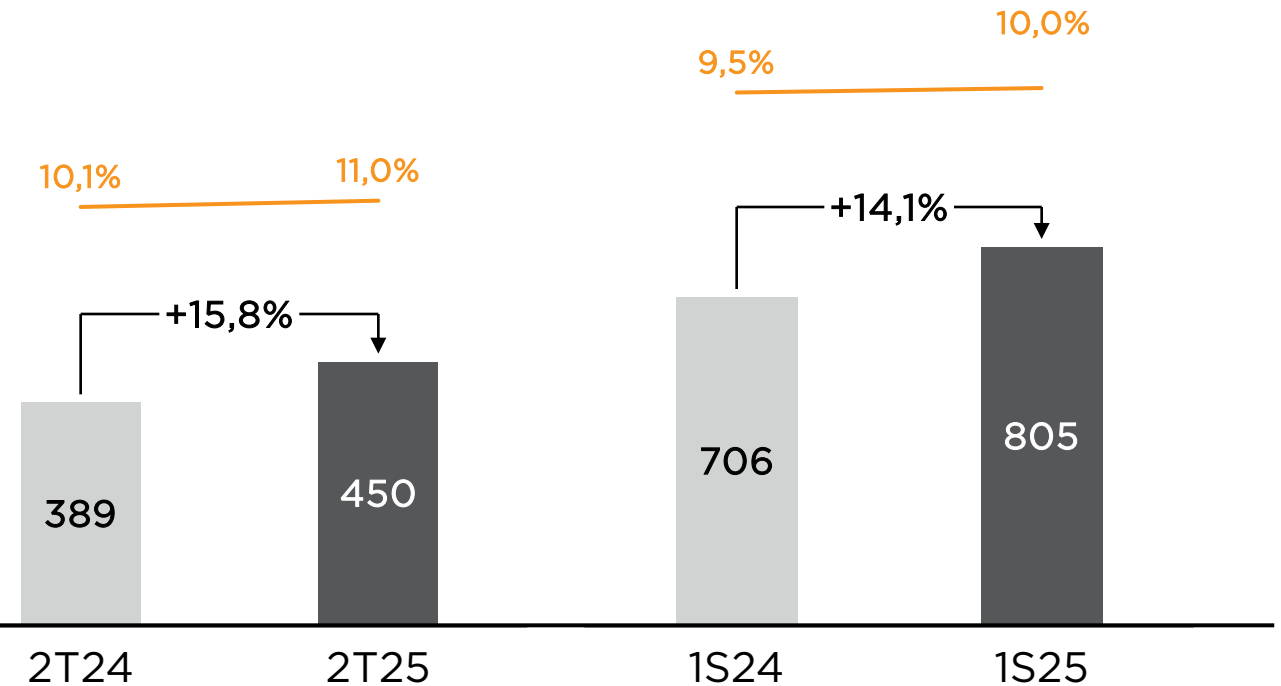

Nota: Informações financeiras reportadas em milhões de reais (R\$).

DÍVIDA BRUTA: SUSTENTANDO UMA POSIÇÃO FINANCEIRA SÓLIDA

Composição

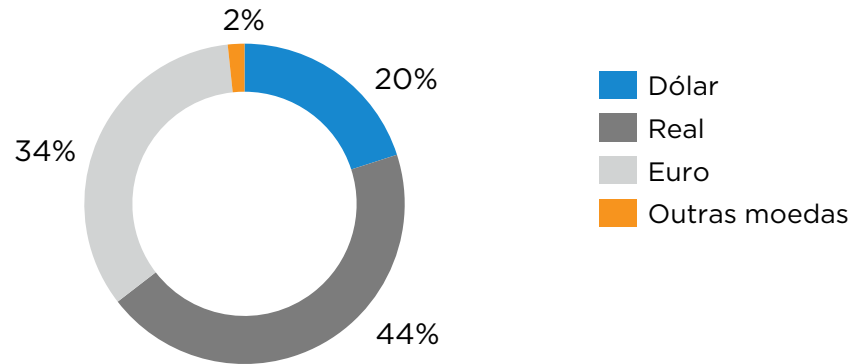

Prazo

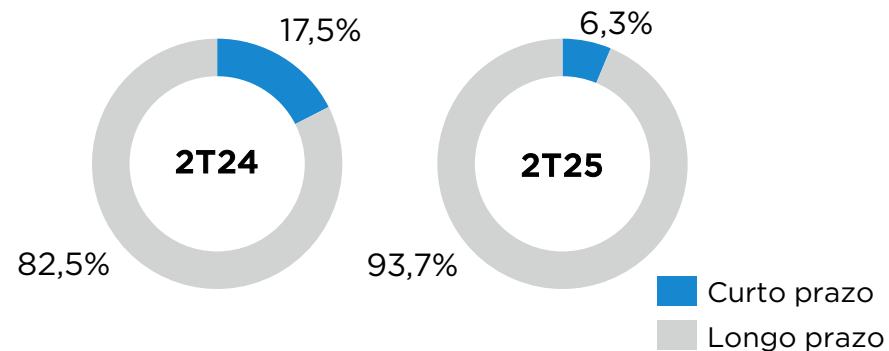

Torre de vencimentos¹

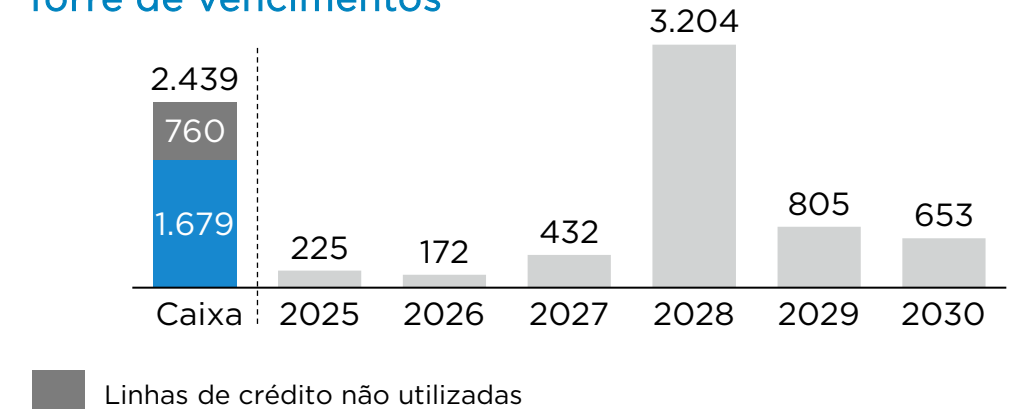

Custo

	2T24	2T25
Custo (BRL)	CDI + 1,9%	CDI + 1,2%
Custo (EUR)	4,2	3,5
Custo (USD)	5,8	5,6
Prazo médio	4,2 anos	3,6 anos

Linha da Finep de R\$ 357 milhões, com R\$ 300 milhões ainda pendentes de reembolso, com custo de TR + 2,3% a.a.

¹Inclui instrumentos financeiros.

Nota: Informações financeiras reportadas em milhões de reais (R\$).

IMPULSIONANDO A INOVAÇÃO INDUSTRIAL: COM APOIO DA FINEP

A FINEP promove o desenvolvimento econômico e social por meio do incentivo à ciência, tecnologia e inovação, oferecendo recursos financeiros reembolsáveis e não reembolsáveis.

Essa parceria reforça não apenas nosso compromisso com o crescimento sustentável, mas também com o desenvolvimento contínuo da Maxion por meio da inovação

Estamos implementando soluções em automação, transformação digital e inteligência artificial em nossos processos industriais, fortalecendo nossa competitividade e contribuindo para uma indústria mais eficiente e sustentável



RENATO BRIGHENTI

CEO

MAXION STRUCTURAL
COMPONENTS



AGENDA

- Destaques Maxion Structural Components
- Crescimento
- Competitividade
- Pessoas
- Sustentabilidade acessível

MAXION STRUCTURAL COMPONENTS VISÃO GERAL



Componentes estruturais
para veículos comerciais



Cabines estruturais e
"Classe A" para caminhões



Chassis para
caminhões, ônibus,
picapes e SUVs

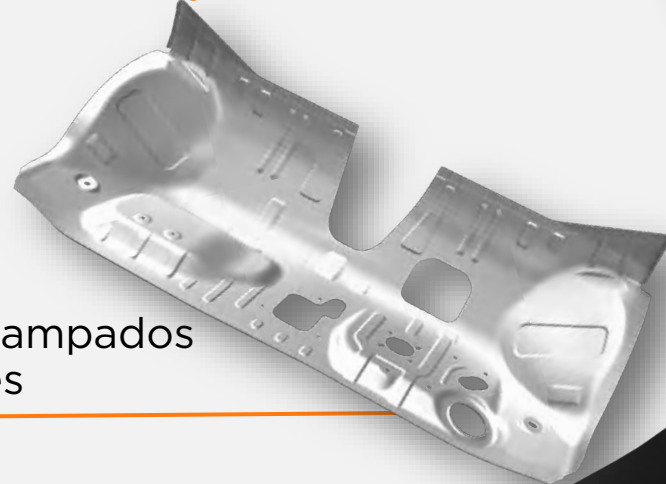

Componentes estampados
para veículos leves



Longarinas
para caminhões e ônibus

NOVA LINHA *ROLLFORMER* AUTOMATIZADA: MELHORIA DE EFICIÊNCIA E PRODUTIVIDADE

Em parceria com a FINEP, o projeto em Cruzeiro visa trazer inovação para os produtos e modernizar a linha de produção de longarinas, proporcionando ganhos em capacidade, eficiência e produtividade



Imagem ilustrativa

MELHORANDO + PREPARANDO-NOS: PARA O CRESCIMENTO FUTURO

O investimento para aumentar a eficiência e expandir a capacidade da fábrica de Castaños, nos posiciona para o crescimento no mercado norte-americano de longarinas para veículos comerciais



TRANSFORMAÇÃO CASTAÑOS



Projeto executado em múltiplas fases

CRESCIMENTO: SOLUÇÕES INOVADORAS PARA HÍBRIDOS E ELÉTRICOS



HARBINGER MOTORS *STEP-IN EV VANS*

Longarinas
para Classes 4 - 6



EMPRESA AMERICANA MULTINACIONAL DE VEÍCULOS ELÉTRICOS

Longarinas para caminhões
Classe 8

CRESCIMENTO: SOLUÇÕES INOVADORAS

Parceria com a Novelis
(América do Norte)



FOCO NO SEGMENTO DE VEÍCULOS DE EMISSÃO ZERO

Utilizando os ativos atuais e a capacidade de engenharia para criar uma nova oportunidade de receita focada na eletrificação, com o objetivo de oferecer uma solução completa para OEMs

As cotações em andamento incluem chassis para veículos elétricos, soluções de *retrofit* e compartimentos para baterias para veículos comerciais, como caminhões, ônibus e vans com acesso facilitado



BATTERY HOUSING EM ALUMÍNIO

Estrutura do compartimento da bateria em alumínio 35% mais leve com os mesmos requisitos técnicos— 11% maior densidade de energia

MAXION
InVolt

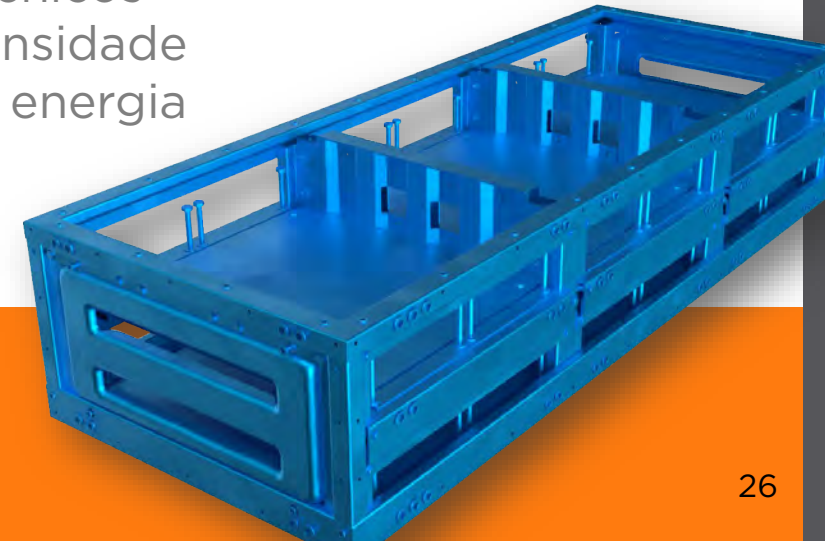

AUMENTANDO A COMPETITIVIDADE: POR MEIO DA IA E DA DIGITALIZAÇÃO

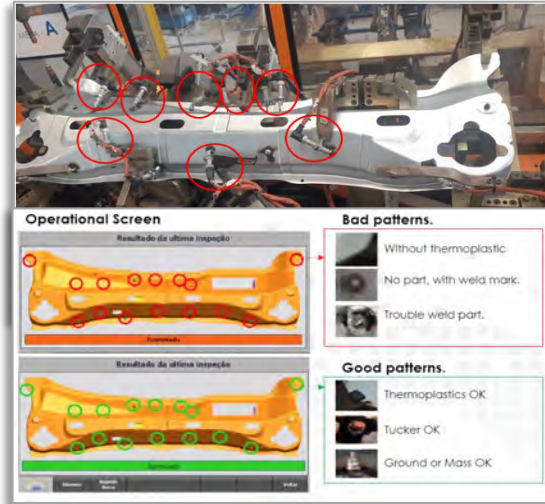

Sistema de visão com IA

Usando um sistema de visão habilitado para IA em células de soldagem para identificar a presença e o posicionamento de pinos durante processo de soldagem



Otimização de estoques

Usando IA e três anos de dados para ajustar os parâmetros de estoque para lidar com eficiência com a demanda, manutenção, rupturas de estoque e melhorar o fluxo de caixa



Portal da rentabilidade

Aproveitando a configuração SAP para impulsionar melhorias substanciais na rentabilidade e na gestão de custos

AUMENTAR A COMPETITIVIDADE: AS PESSOAS NO CENTRO



Formação de líderes das Equipes de Trabalho Naturais (NWT)



Primeira ideia impressa a partir do Hackathon de Impressão 3D

489 IDEIAS
ENVIADAS NA CAMPANHA DE IMPRESSÃO 3D
DO HACKATHON

Aumento de
303%
IDEIAS ENVIADAS
PARA O
PROGRAMA ÁGIL
(em comparação
com 2024)

Nossos funcionários são fundamentais para a inovação, transformando ideias em projetos práticos que aumentam a produtividade e a competitividade da Maxion.

SUSTENTABILIDADE: ACESSÍVEL



PAINÉIS SOLARES CASTAÑOS

Durante o primeiro semestre de 2025, foram instalados painéis solares para fornecer eletricidade diretamente à fábrica de Castaños.

Economia: 280 tCO₂/ano;
Fornecimento: 927 MWh/ano

CERTIFICAÇÃO DE DESPERDÍCIO ZERO

Em 2024, a fábrica de Contagem recebeu a Certificação Resíduos Zero após reformular suas práticas de descarte e gestão de resíduos



A fábrica de Contagem alcançou mais de 90% de redução de CO₂ (Escopo 1 e 2)*

*Nota: em comparação com *baseline* de 2019

RESUMO DA ESTRATÉGIA COMPETITIVA

- Foco no *core-business*
- Manter o negócio no caminho certo, transformando nossas operações
- Entregar valor para clientes atuais e novos, oferecendo soluções inovadoras e sustentáveis
- Estar pronto para o futuro

MARK GERARDTS

CEO

MAXION WHEELS



AGENDA

- Líder no setor com mais de 100 anos de sucesso comprovado
- Alcançando crescimento por meio de ganhos de *marketshare* e vendas de valor agregado
- Capitalizando a dinâmica do setor por meio de operações ágeis e execução robusta
- Capacitando talentos para o sucesso do negócio



LIDERANÇA COMPROVADA NO SETOR

Mais de 100 anos de inovação

Experiência e presença global em rodas

Confiança reconhecida globalmente pelos líderes
de OEMs

Um parceiro de engenharia confiável

Cadeia de suprimento diversificada e escalável



**MOTORES DE
CRESCIMENTO**

**EXECUÇÃO
IMPLACÁVEL**

Produtos
acessíveis
com valor
agregado

Novos
segmentos

Novos
clientes



Excelência
operacional
Tecnologias
inteligentes



Presença local
para o
mercado local

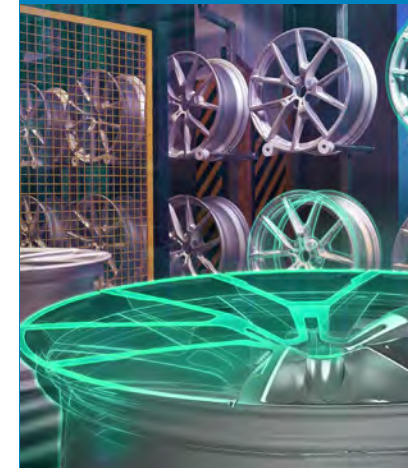

Resiliente



MOTORES DE CRESCIMENTO: PRODUTOS ACESSÍVEIS COM
VALOR AGREGADO

PRODUTOS ACESSÍVEIS COM VALOR AGREGADO: SOLUÇÕES PARA VEÍCULOS LEVES

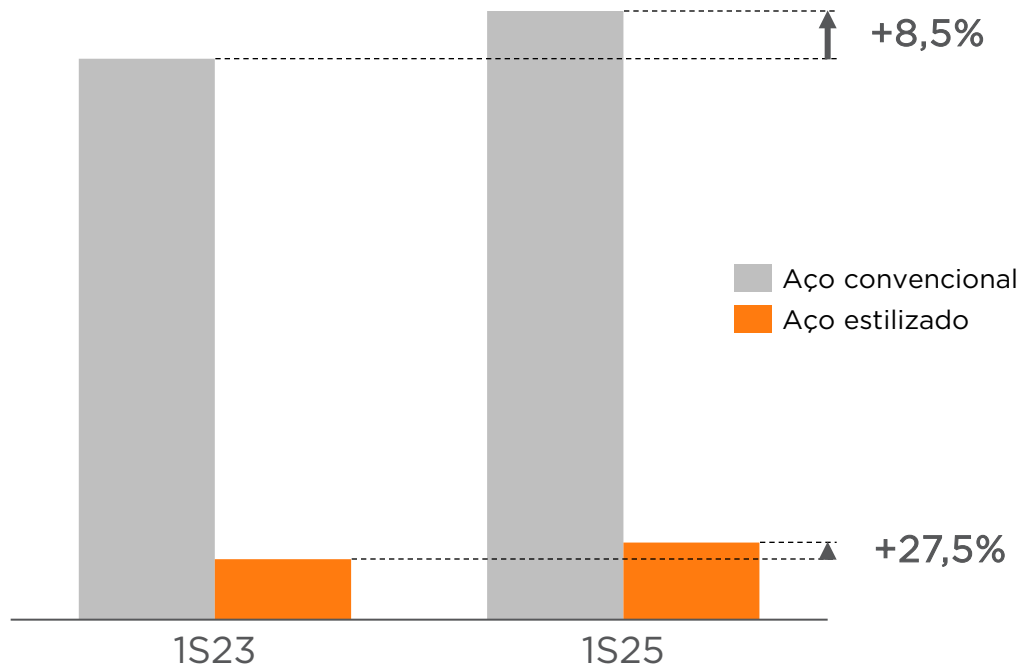

PRODUTOS ACESSÍVEIS COM VALOR AGREGADO: AUMENTO DAS VENDAS COM NOVAS TECNOLOGIAS

Maxion FUSION: combinação de materiais e funcionalidade para agregar valor; 2 programas de co-desenvolvimento com clientes em andamento

Tecnologia NVH Wheel: ajuste do disco da roda de aço e do perfil do aro para reduzir o ruído; volume adicional significativo in 2025



Maxion
FUSION

Tecnologia NVH
Wheel

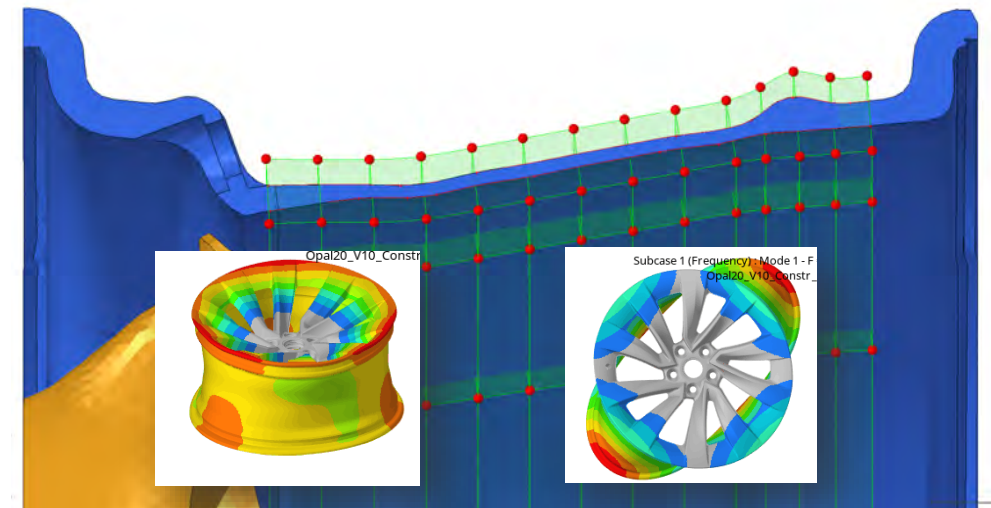



MOTORES DE CRESCIMENTO: NOVAS APLICAÇÕES



NOVAS APLICAÇÕES: CRESCIMENTO COM RODAS ESPECIAIS

Atendendo a diversas aplicações de nicho, incluindo agricultura, empilhadeiras e defesa, com expertise em rodas altamente requisitada

Fornecendo para **o setor de defesa a partir de um número crescente** de plantas nas Américas, Europa e Ásia
Produção de **1,2 milhão** de rodas para trailers leves e veículos recreativos em 2024, **3x** a mais comparados a 2019



NOVAS APLICAÇÕES: RODAS COMERCIAIS DE ALUMÍNIO FORJADO

Nova linha de rodas de caminhão de alumínio forjado para OEMs e frotas que buscam uma solução de eficiência de carga otimizada para alto desempenho

Início da produção no fim de 2025

Cartas de intenção de vendas assinadas com diversas OEMs

Rede de distribuição preparada e pronta para vendas

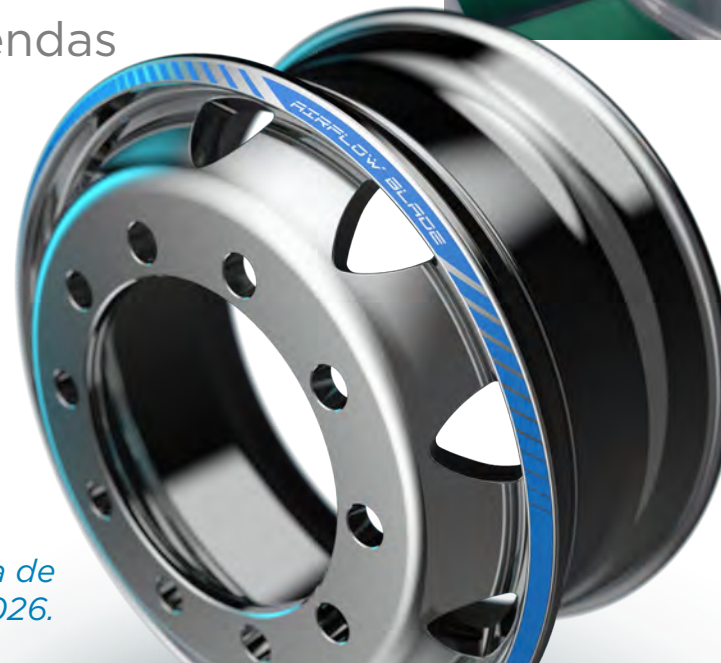

Solução avançada e exclusiva de acabamento, com lançamento em 2026.



MOTORES DE CRESCIMENTO: NOVOS CLIENTES

NOVOS CLIENTES: UTILIZANDO UM PORTFÓLIO ABRANGENTE E A EXPERTISE PARA EXPANDIR A BASE DE CLIENTES



Fornecimento de rodas para mais de **100+** clientes OEMs diferentes; **conquistamos 24 novos clientes OEMs nos últimos 5 anos – incluindo OEMs chinesas com planos de expansão global**

A produção OEM chinesa fora da China deve dobrar nos próximos 5 anos; Maxion está bem posicionada para **conquistar essas novas oportunidades**

Expansão contínua da expertise em rodas, com a execução de centenas de programas de rodas por ano; atuando como especialistas internos em rodas para **muitos novos clientes**

Aumento de 7% de novos negócios conquistados no 1S25 em comparação com 1S24

EXECUÇÃO INCANSÁVEL: DESDE OPERAÇÕES ÁGEIS, PADRÕES GLOBAIS E FORTE DISCIPLINA



Excelência operacional

Melhoria diligente dos processos de produtividade para alcançar um desempenho superior

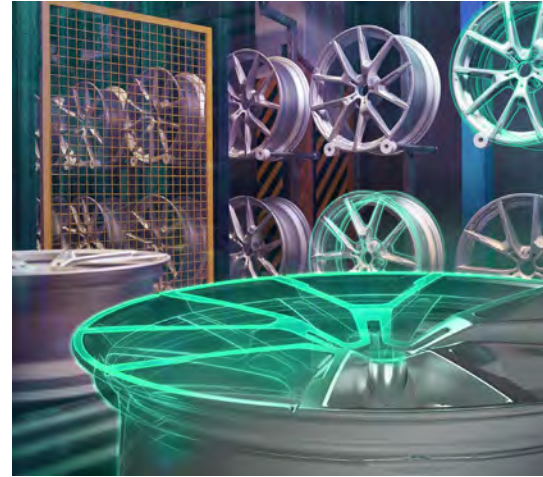

Processos e ferramentas inteligentes

Aprimorando o desempenho dos negócios e atraindo os melhores talentos, aproveitando ferramentas digitais avançadas e estratégias baseadas em dados



Força de trabalho engajada

Impulsionando a lucratividade com uma equipe positiva e engajada

EXECUÇÃO INCANSÁVEL: EXCELÊNCIA OPERACIONAL QUE IMPULSIONA A PREVISIBILIDADE DO DESEMPENHO

Os padrões globais do Sistema de Gestão M2S, juntamente com planos de ação e auditorias mensais, impulsionam o desempenho da produtividade

Mais de **2.200** certificados *belts*; **130** líderes *Black Belts* eliminando desperdícios e melhorando a produtividade

Mais de **450** equipes de trabalho naturais em todo o mundo; evento anual de premiação das melhores práticas acelera a adoção em outras fábricas; **748** projetos avaliados em 2024

Fonte: Relatório interno Iochpe-Maxion.

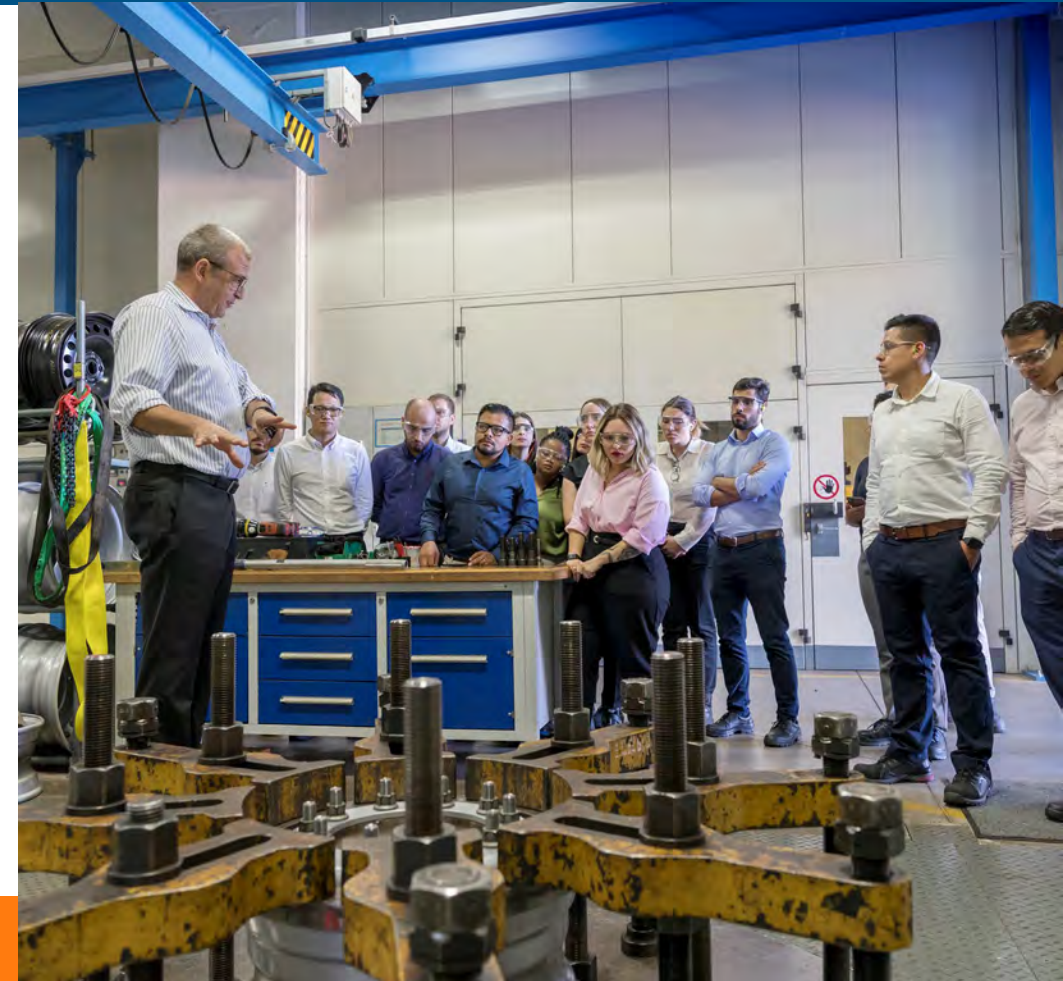

EXECUÇÃO INCANSÁVEL: PROCESSOS E FERRAMENTAS INTELIGENTES PARA ACELERAR A EFICIÊNCIA

A implementação global de ferramentas digitais focadas em manutenção, energia, planejamento de materiais e aquisição aumenta a flexibilidade operacional, a velocidade e a eficiência da Maxion

Reconhecida consistentemente por programas de prêmios de prestígio do setor por nosso foco e avanço em iniciativas de digitalização; **30** prêmios em 2024

O número de projetos de digitalização está aumentando à medida que mais oportunidades de redução de custos são identificadas

Fonte: Relatório interno Iochpe-Maxion.



EXECUÇÃO INCANSÁVEL: FORÇA DE TRABALHO ENGAJADA E CAPACITADA, PRONTA PARA UM FUTURO DINÂMICO

Investindo em nossa vantagem competitiva com uma força de trabalho próspera e engajada; **86%¹** de índice de engajamento (**9 p.p.**) acima das empresas de alto desempenho

Capacitar os funcionários para gerar ideias e soluções inovadoras que impulsionem a criação de valor; **558²** ideias em 2024

Adaptando-nos às mudanças tecnológicas e abordando as lacunas de competências da força de trabalho para preparar o negócio para o futuro



Fonte: ¹ Pesquisa global sobre engajamento dos funcionários da Korn Ferry, 2023.
² Relatório interno da Iochpe-Maxion de 2023.

UMA ABORDAGEM BEM-SUCEDIDA

- Adaptando-se às mudanças do setor por meio de operações flexíveis e execução incansável
- Alcançar os objetivos de crescimento através da conquista de novos clientes, aumento da participação no mercado e melhoria das vendas por meio de ofertas inovadoras e de maior valor agregado
- Investir e capacitar talentos para impulsionar o sucesso dos negócios

PIETER KLINKERS
PRESIDENTE E CEO
IOCHPE-MAXION



SUSTENTABILIDADE ACESSÍVEL: VANTAGEM COMPETITIVA

NOSSO PESSOAL, NOSSO PROPÓSITO: CELEBRANDO O CORAÇÃO DA MAXION

Liderando uma força de trabalho qualificada e multidimensional com **mais de 40 nacionalidades**

Estabelecer um ambiente que incentive **envolvimento e a capacitação**

Desenvolvendo talentos com foco nas estratégias de negócios atuais e futuras

Executando o programa We Care para abordar a importância de nossas responsabilidades culturais, de bem-estar, ambientais e sociais



DIVERSIDADE E INCLUSÃO

127 atividades em 2024

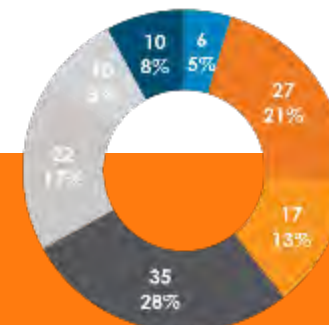

IMPACTO SOCIAL

116 atividades em 2024

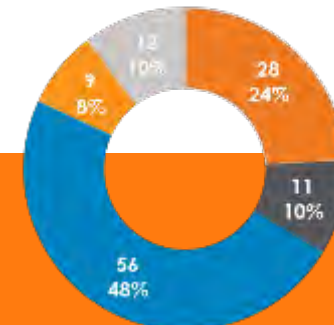

BEM ESTAR

109 atividades em 2024

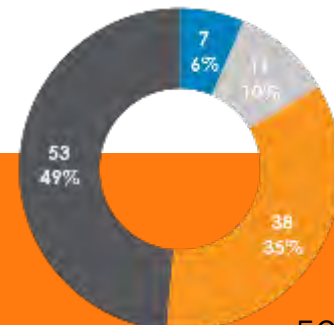

TRANSFORMANDO VIDAS ATRAVÉS DA EDUCAÇÃO: COMEMORANDO 35 ANOS DA FUNDAÇÃO IOCHPE

DESTAQUES DE 2024



Mais de 1.000

Jovens atendidos

Mais de 4.300

Voluntários ativos



Unidades no Brasil,
México e Índia



45

Empresas parceiras



ENCERRAMENTO

- A MAXION está em uma posição favorável dado a sua forte presença global e operações ágeis
- Foco em fazer mais com menos. Projetos menores, mas com retorno rápido, mais aplicações, mais novos produtos, mais IA/Transformação Digital
- Impulso contínuo para crescer e fortalecer o balanço patrimonial, entregando valor para o acionista

**OS MERCADOS SÃO DINÂMICOS, A MAXION ESTÁ
COMPROMETIDA COM A PERFORMANCE**

IMPULSIONANDO O CRESCIMENTO SUSTENTÁVEL: POR MEIO DE FORÇA ESTRATÉGICA E DESEMPENHO RESILIENTE

“
*Você não consegue ultrapassar 15
carros em um dia ensolarado... mas
pode quando está chovendo*

Ayrton Senna

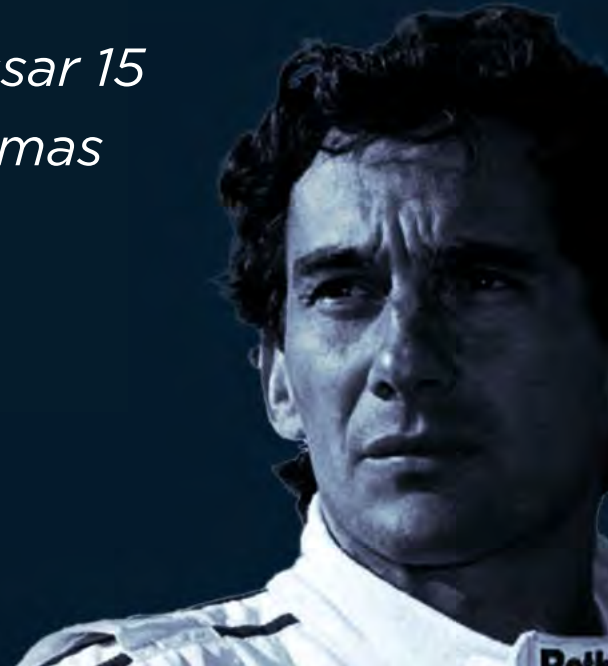

AGENDA

- Welcome and Introductions
- Iochpe-Maxion
- Maxion Structural Components
- Maxion Wheels
- Closing and Q&A

TODAY'S PRESENTERS

Renato Salum

CFO and IRO
lochpe-Maxion

Pieter Klinkers

President and CEO
lochpe-Maxion

Rodrigo Caraça

IR Senior Manager
lochpe-Maxion

Mark Gerardts

CEO
Maxion Wheels

Renato Brighenti

CEO
Maxion Structural
Components

PIETER KLINKERS
PRESIDENT AND CEO
IOCHPE-MAXION



ABOUT
IOCHPE-
MAXION

Most global wheel
supplier in the world
with approx. **50 million**
wheels produced annually

Leading supplier of
automotive structural
components in the
Americas



Manisa, Türkiye



Castaños, Mexico

33 Plants
14 Countries
+17,000 Employees

Many new,
innovative and
cost-competitive
products, in all
regions: global
expertise applied
locally



OPERATING TWO BUSINESSES: EXPLORING MORE SYNERGIES



Production of wheels for light and commercial vehicles, agriculture, defense, material handling and off-highway applications

Approx. **78%**
of net revenue



More synergies in core processes like Innovation, Product Development, Commercial, Supply Chain, Sustainability, Human Resources, AI/DT



Production of structural components for commercial and light vehicles

Approx. **22%**
of net revenue

DELIVERING VALUE: ACROSS THE GLOBE

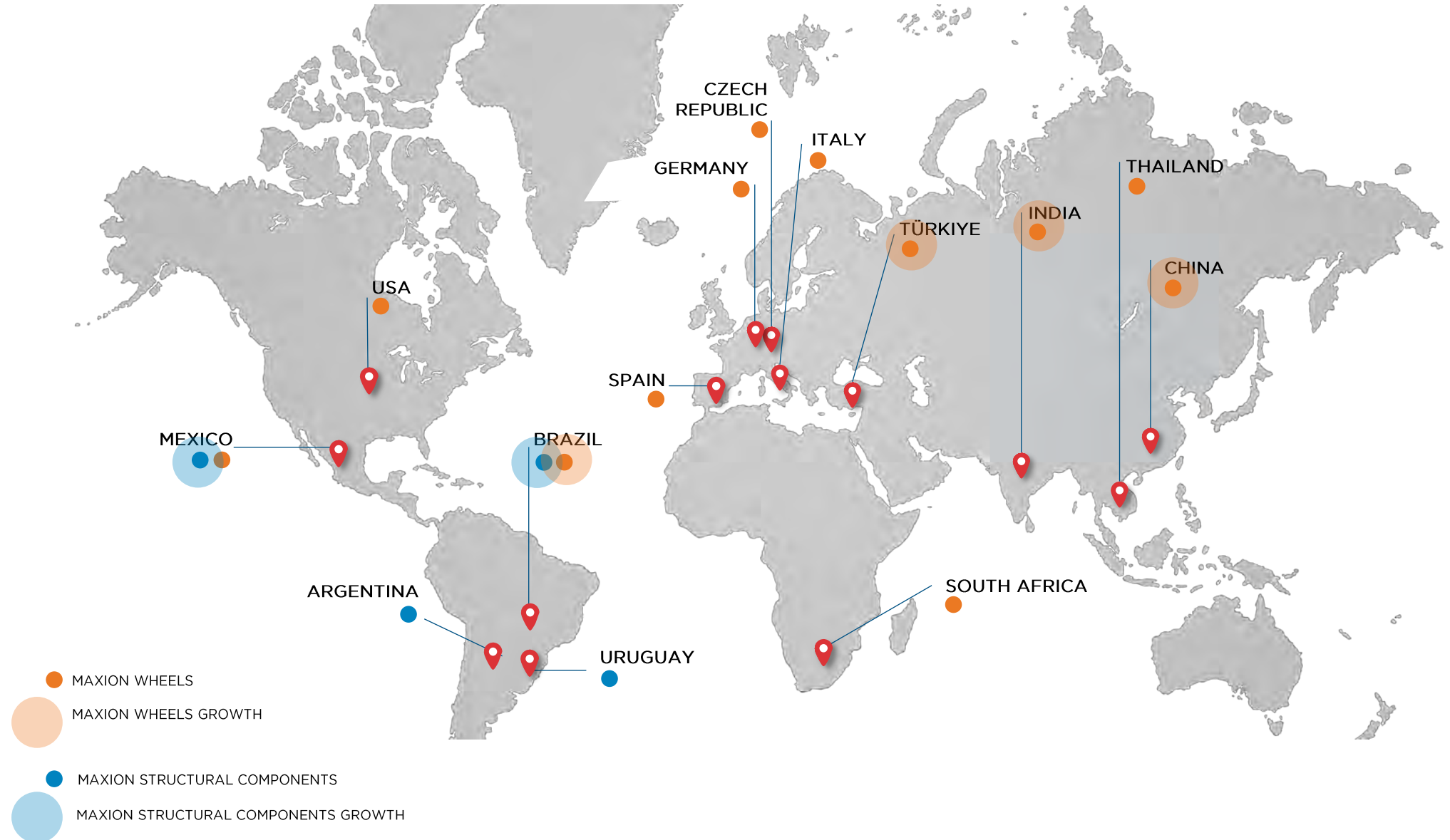



TURNING DYNAMICS INTO SHAREHOLDER VALUE: RESILIENCE

- Strategic global presence with regional market focus
- Complete and innovative product portfolio
- Continued focus on shareholder value
 - Executing operational efficiency
 - Outpacing the market
 - Potential for smart growth, @ existing infrastructure

RENATO SALUM

CFO AND IRO
IOCHPE-MAXION



AGENDA

- Global Vehicle Production
- Financial Performance
- 2Q25 Earnings Results
- Sustaining Financial Discipline

MARKET: GLOBAL VEHICLE PRODUCTION

Light Vehicles¹
(Unit in millions)

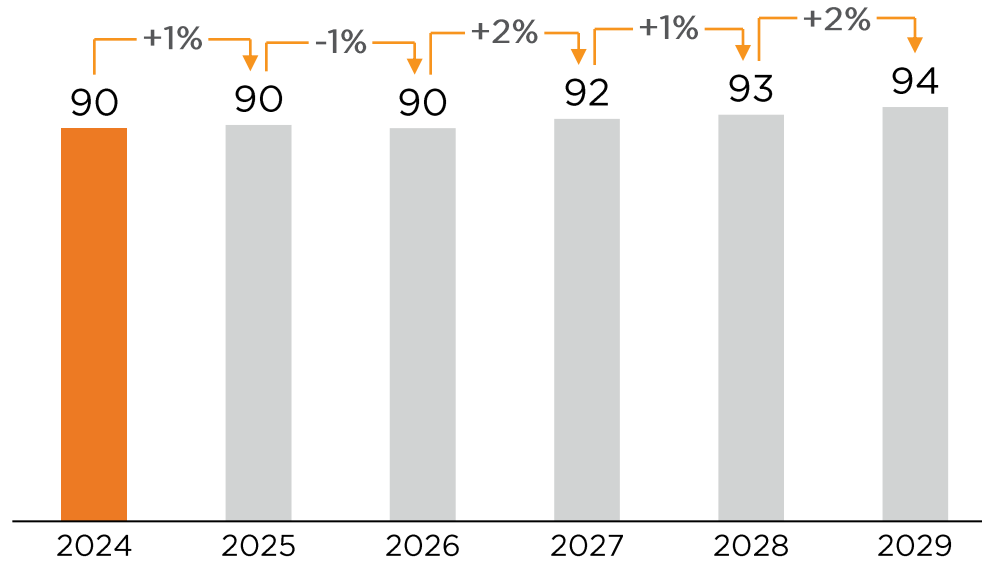

Global production ex-China - var.

-1% -1% +3% +2% +3%

Commercial Vehicles²
(Unit in thousands)

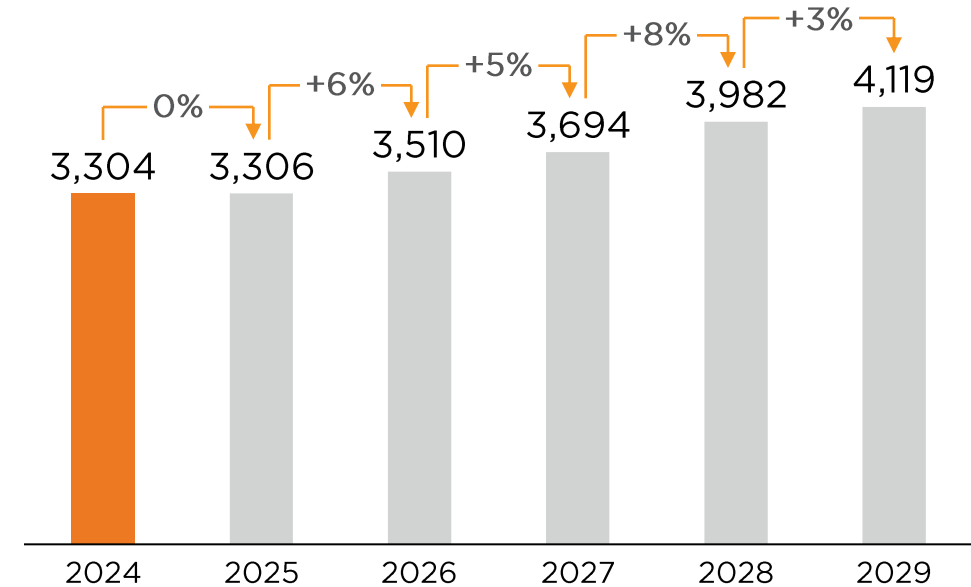

-5% +7% +4% +8% +2%

FINANCIAL HIGHLIGHTS: DELIVERING CONSISTENT PERFORMANCE

2Q25



Net Revenue

R\$ 4.1 billion



Gross Profit

R\$ 535 million
with gross
margin of 13.0%



EBITDA

R\$ 450 million
with a margin of
11.0%



Net Income

R\$ 87 million with
a margin of 2.1%



Leverage

Net debt/EBITDA
of 2.38x

1H25



Net Revenue

R\$ 8.0 billion



Gross Profit

R\$ 978 million
with gross
margin of 12.2%



EBITDA

R\$ 805 million
with a margin of
10.0%



Net Income

R\$ 98 million with
a margin of 1.2%

NET REVENUE: SUSTAINED GROWTH MOMENTUM

1H25

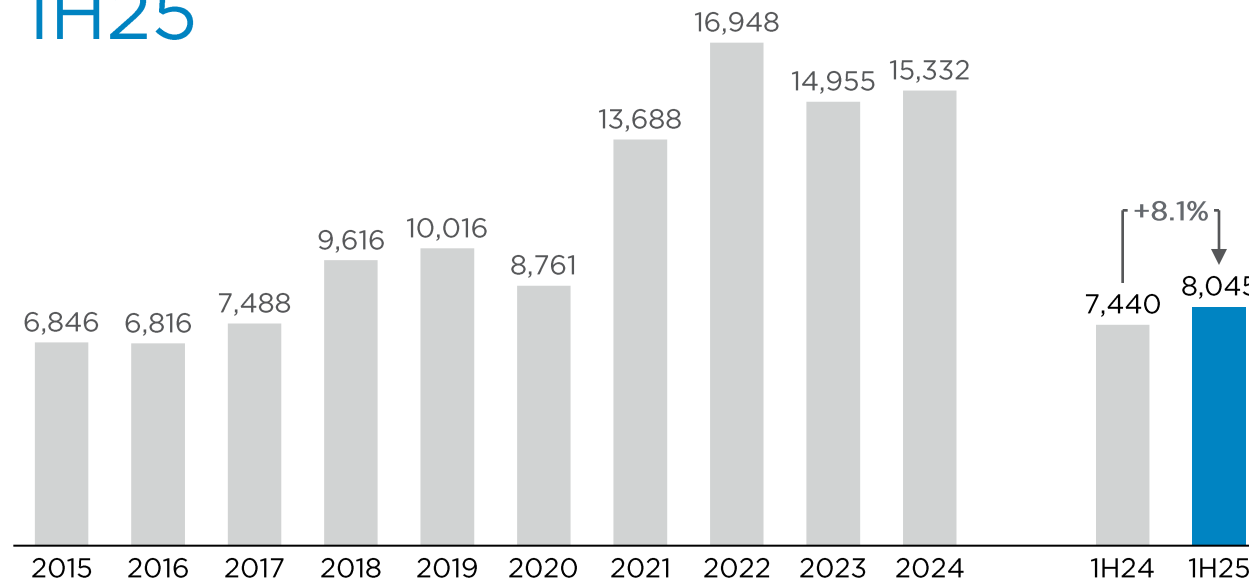

Revenue by Region (%)

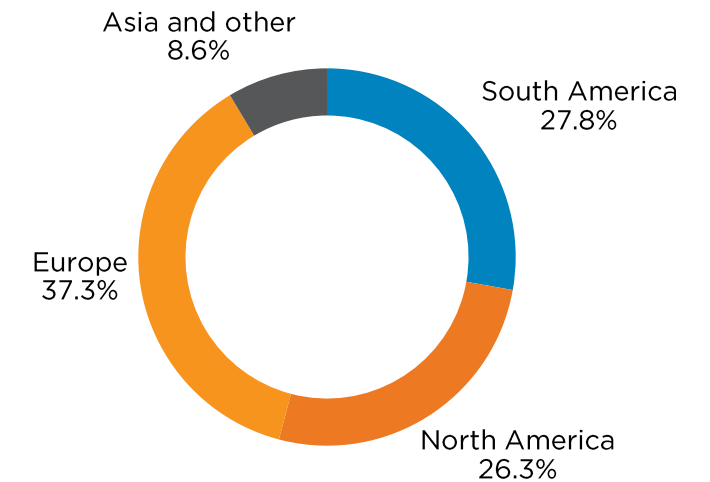

2Q25 REVENUE: BY PRODUCT

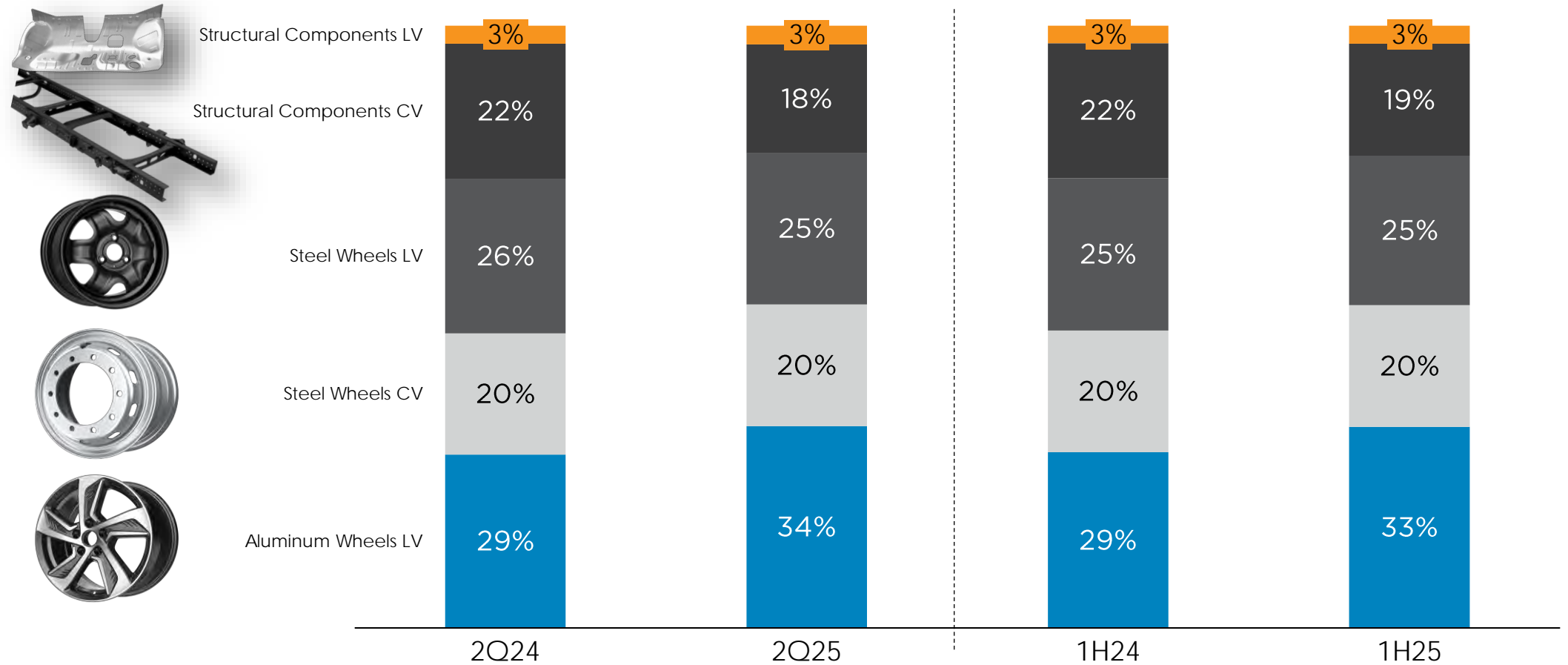

LV: light vehicles
CV: commercial vehicles

2Q25 REVENUE: BY CUSTOMER

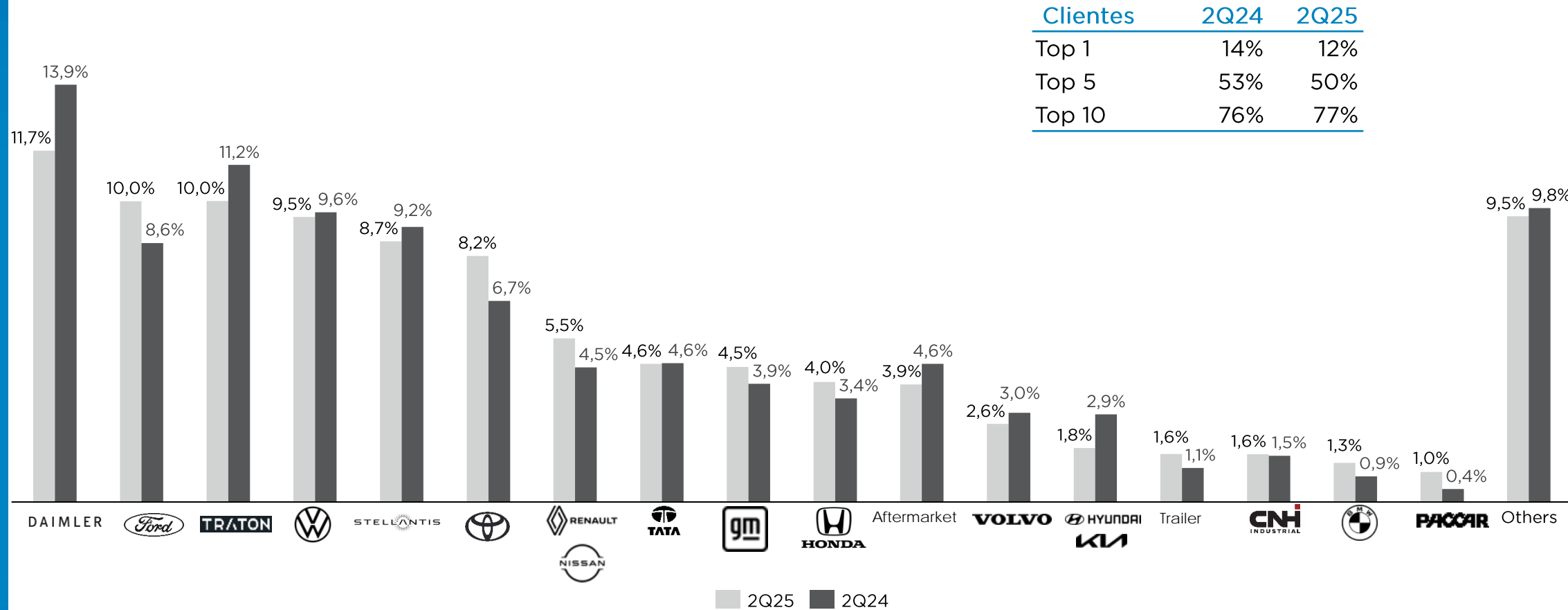

EBITDA AND EBITDA MARGIN (%): DRIVING PROFITABILITY WITH DISCIPLINE

Growth of 0.9 p.p. in the EBITDA margin in 2Q25 and 0.5 p.p. in 1H25

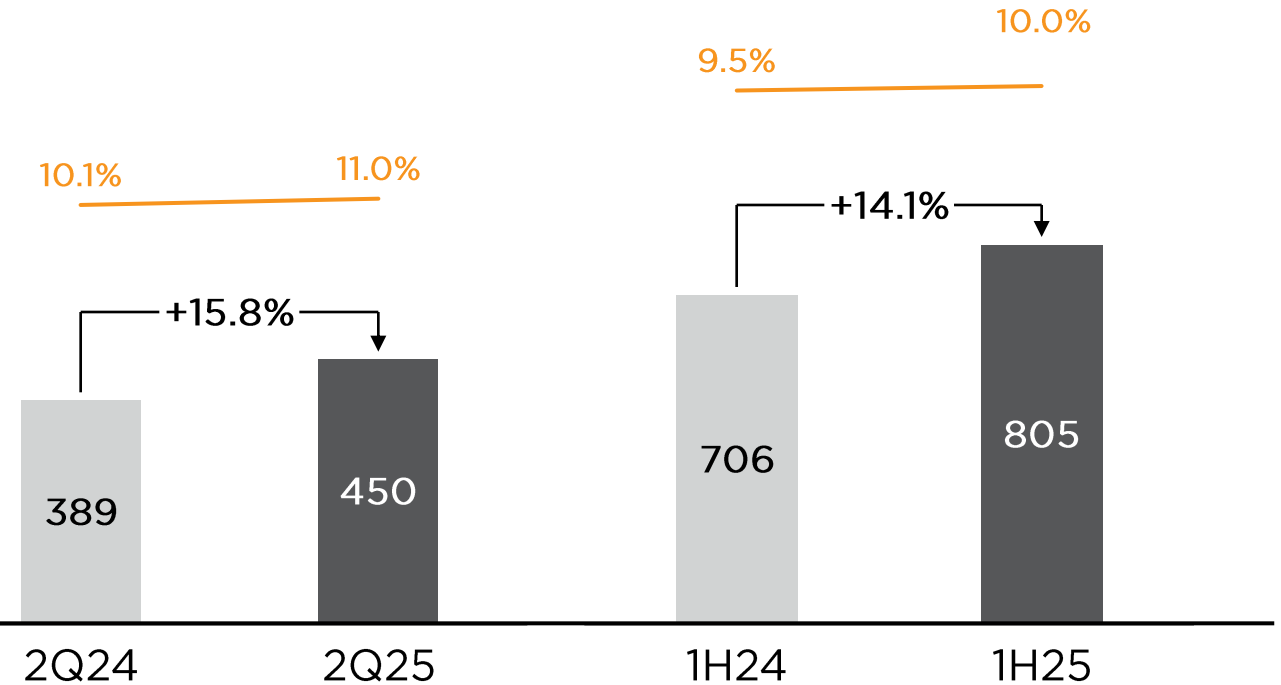

Note: Financial information reported in Brazilian Reals (R\$) millions.

GROSS DEBT: MAINTAINING A SOLID FINANCIAL POSITION

Composition

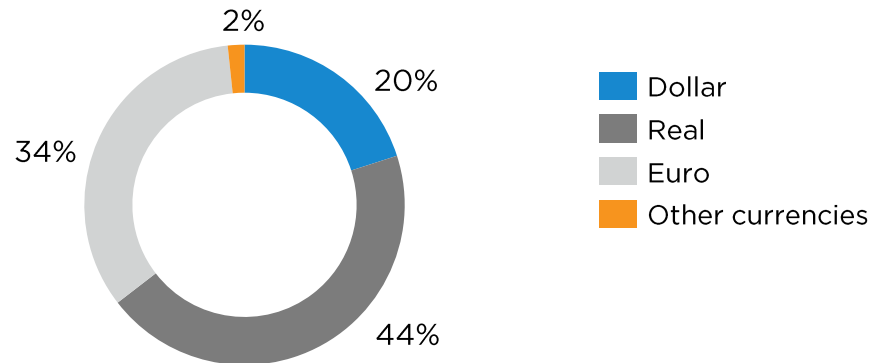

Maturity¹ (in millions)

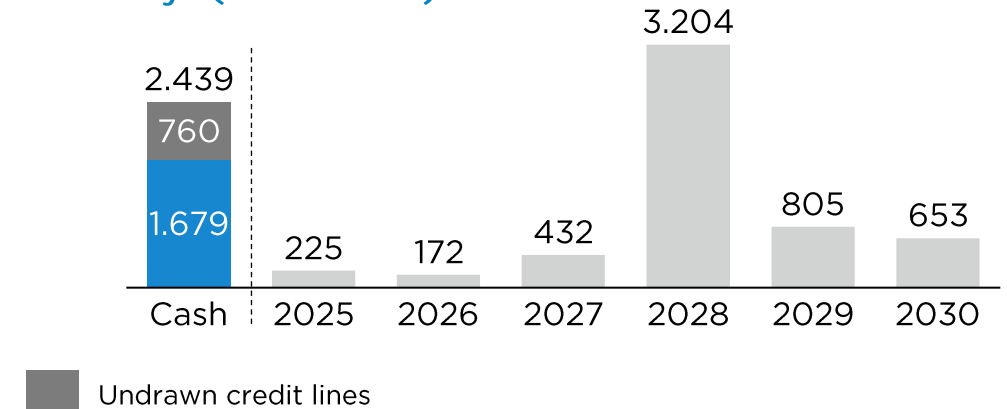

Term

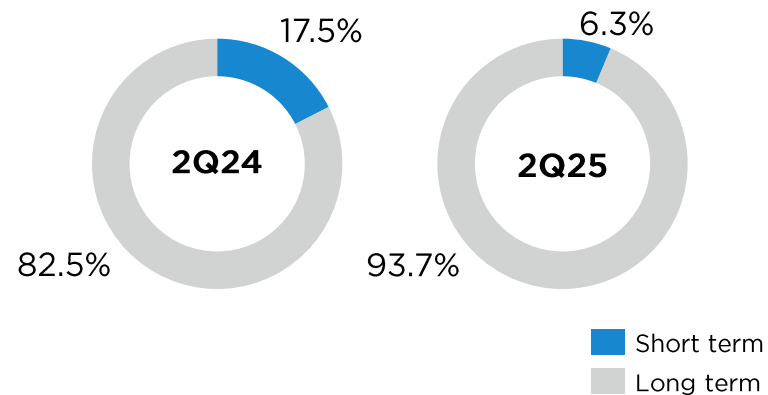

Cost

	2024	2025
Cost (BRL)	CDI + 1.9%	CDI + 1.2%
Cost (EUR)	4.2%	3.5%
Cost (USD)	5.8%	5.6%
Average time	4.2 years	3.6 years

Finep line of R\$ 357M with R\$ 300M still pending reimbursement, with a cost of TR + 2.3% per year.

¹Includes financial instruments.

Note: Financial information reported in Brazilian Reals (R\$) millions.

LEVERAGING INDUSTRY INNOVATION: WITH FINEP SUPPORT

FINEP drives economic and social development by supporting science, technology, and innovation with reimbursable and non-reimbursable funding

Our partnership reinforces our commitment to sustainable growth and Maxion's ongoing innovation through the adoption of automation, digital transformation, and AI in our processes to boost competitiveness and promote a more efficient, sustainable industry



RENATO BRIGHENTI

CEO

MAXION STRUCTURAL
COMPONENTS



AGENDA

- Maxion Structural Components At-A-Glance
- Growth
- Competitiveness
- People
- Affordable Sustainability

MAXION STRUCTURAL COMPONENTS AT-A-GLANCE



Chassis for trucks,
buses, pick-ups
and SUVs



Structural parts for
commercial vehicles

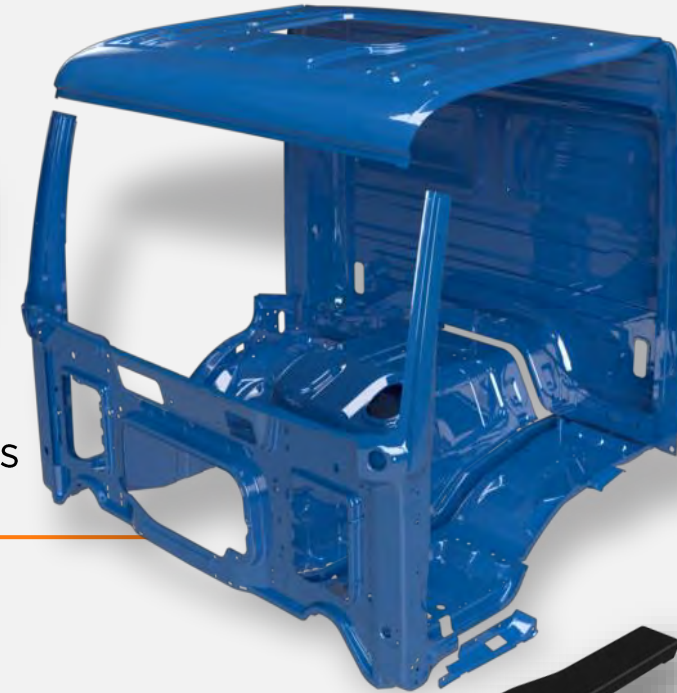

Structural and "Class
A" truck cabins



Stamped parts
for light vehicles



Side rails for truck
and buses

NEW AUTOMATED ROLLFORMER LINE: IMPROVE EFFICIENCY AND PRODUCTIVITY

With a FINEP investment, the Cruzeiro rollformer project aims to innovate products and modernize the side rail production line providing gains in capacity, efficiency and productivity

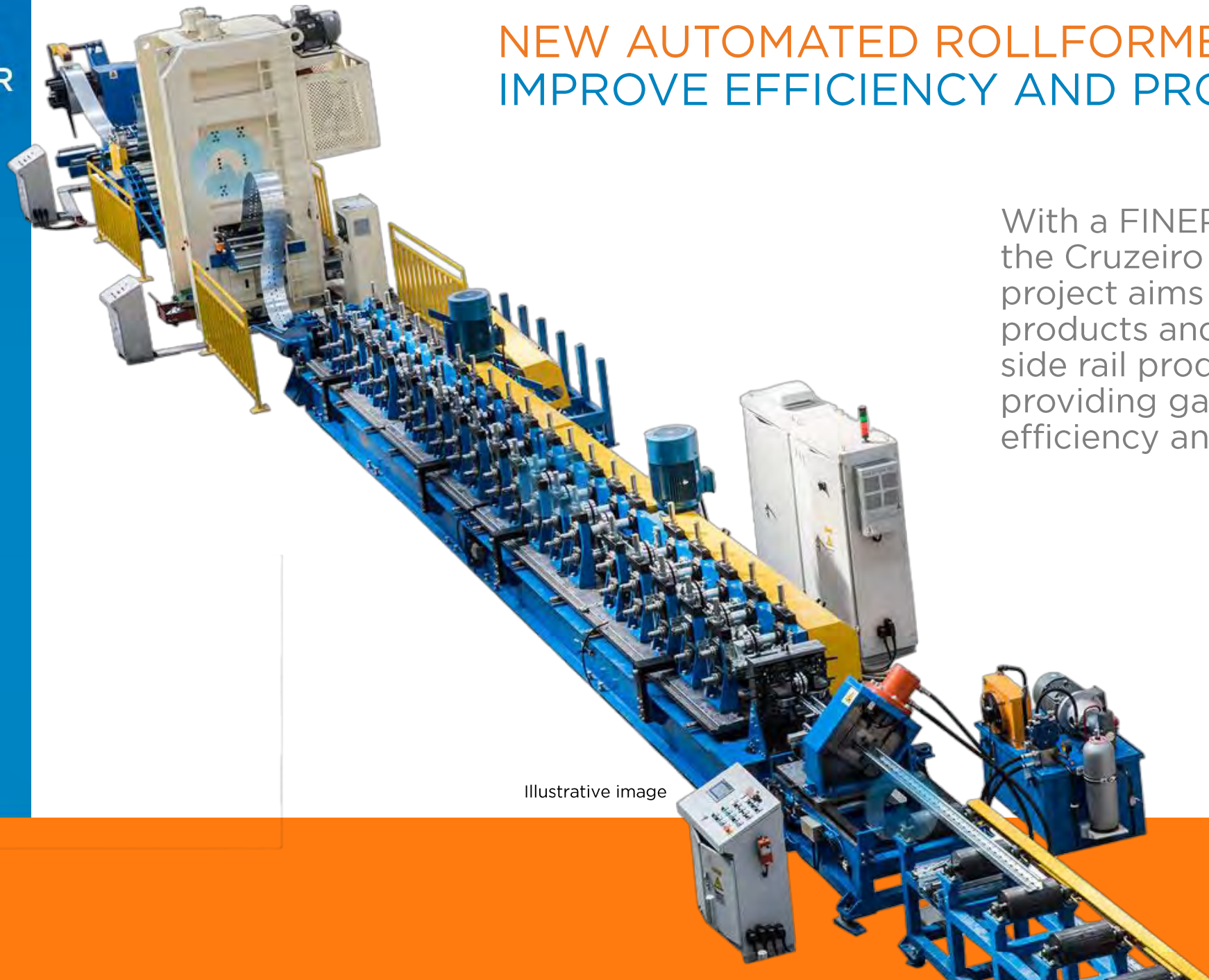

Illustrative image

GETTING BETTER + PREPARING FOR FUTURE GROWTH

Investment is being completed to boost efficiency and expand capacity at the Castaños plant, positioning it for growth in North America's CV side rail market



CASTAÑOS TRANSFORMATION



*Project
executed
in multiple
phases*

Ready to capture growth in the North American CV market

GROWTH: INNOVATIVE SOLUTIONS FOR HYBRID AND ELECTRIC SEGMENTS



HARBINGER MOTORS STEP-IN EV VANS

Frame rails for Class 4 – 6



AMERICAN MULTINATIONAL AUTOMOTIVE EV COMPANY

Frame rails for Class 8 trucks

GROWTH: INNOVATIVE SOLUTIONS



FOCUS ON ZERO EMISSION VEHICLE SEGMENT

Use current assets and engineering capabilities to create a new revenue opportunity focused on electrification, aims to offer a complete solution for OEMs

On going quotations include EV rolling chassis, retrofit solutions, and battery housing for commercial vehicles such as trucks, buses, and step-in vans

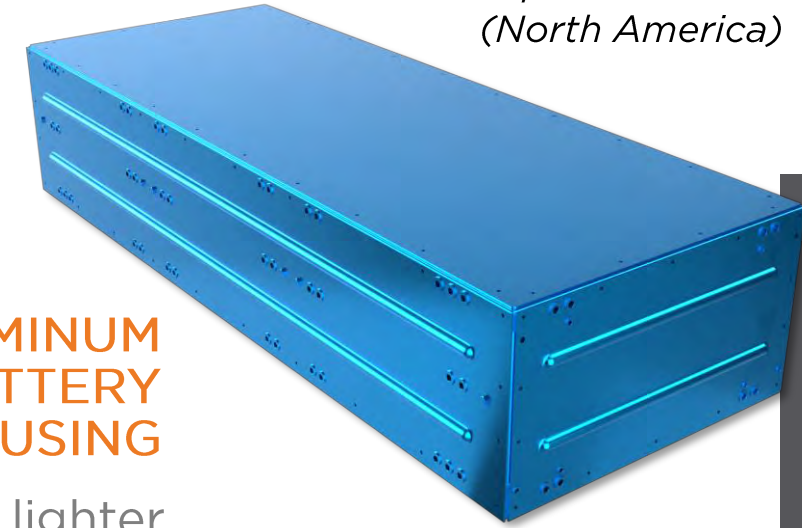

ALUMINUM BATTERY HOUSING

35% lighter aluminum battery compartment structure with the same technical requirements—11% greater energy density

MAXION
InVolt

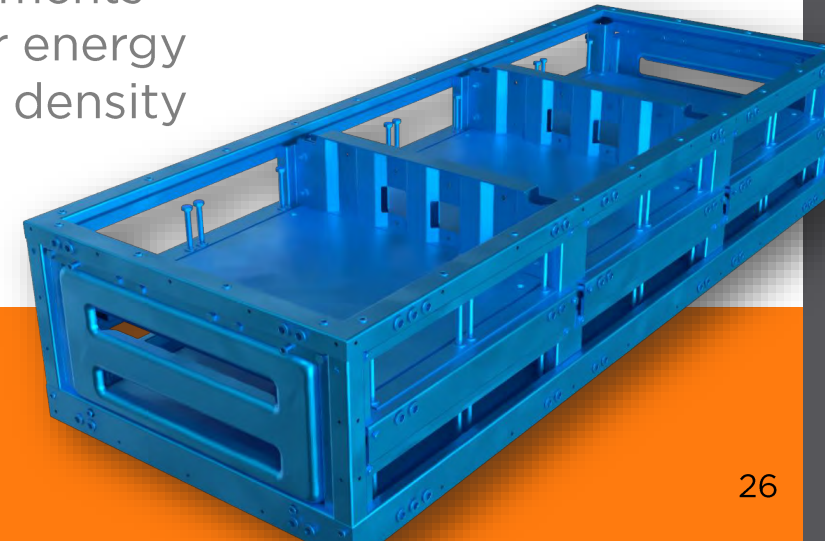

*Partnership with Novelis
(North America)*

INCREASING COMPETITIVENESS: THROUGH AI AND DIGITALIZATION



AI-Powered Vision System

Using an AI-enabled vision system in welding cells to identify the presence and positioning of pins during the welding process



Inventory Optimization

Using AI and three years of data to adjust inventory parameters to efficiently handle demand, maintenance, stockouts, and improve cash flow



Profitability Portal

Leveraging SAP configuration to drive substantial improvements in profitability and cost management

INCREASING COMPETITIVENESS: PEOPLE IN THE CENTER



Training leaders from Natural Work Teams (NWT)



First idea printed from 3D Printing Hackathon

489 IDEAS
SUBMITTED IN THE HACKATHON 3D PRINTING
CAMPAIGN

INCREASE OF
303%
IDEAS SUBMITTED
TO AGILE
CAMPAIGN
(compared to 2024)

Our employees are key to innovation, turning ideas into practical projects that boost Maxion's productivity and competitiveness

AFFORDABLE: SUSTAINABILITY



CASTAÑOS SOLAR PANELS

During the first half of 2025, solar panels were installed to directly supply electricity to the Castaños plant

Saving: 280 tCO₂ /year;
Supply: 927 MWh/year

ZERO WASTE CERTIFICATION

In 2024, the Contagem plant received Zero Waste Certification after overhauling its waste disposal and management practices



Contagem plant reached over 90% of CO₂ reduction (Scope 1 and 2)*

*Note: Compared to 2019 baseline

COMPETITIVENESS STRATEGY SUMMARY

- Focusing on the core business
- Keeping the business on the right track transforming our operations
- Delivering value for both current and new customers offering innovative and sustainable solutions
- Being ready for the future to come

MARK GERARDTS

CEO

MAXION WHEELS



AGENDA

- Leading the industry with 100+ years of proven success
- Achieving growth through market share gains and value-added sales
- Capitalizing on industry dynamics through agile operations and strong execution
- Enabling talent in the success of the business



PROVEN INDUSTRY LEADERSHIP

Over 100 years of innovation
Global wheel expertise and footprint
Trusted by all leading global OEMs
A reliable engineering partner
Diversified and scalable supply



**GROWTH
ENGINES**

**RELENTLESS
EXECUTION**

Affordable
value-add
products

New
segments

New
customers



Operational
excellence

Smart
technologies



Local-for-local
footprint



Resilient



GROWTH ENGINES: AFFORDABLE VALUE-ADD PRODUCTS



AFFORDABLE VALUE-ADD PRODUCTS: LIGHT VEHICLE SOLUTIONS

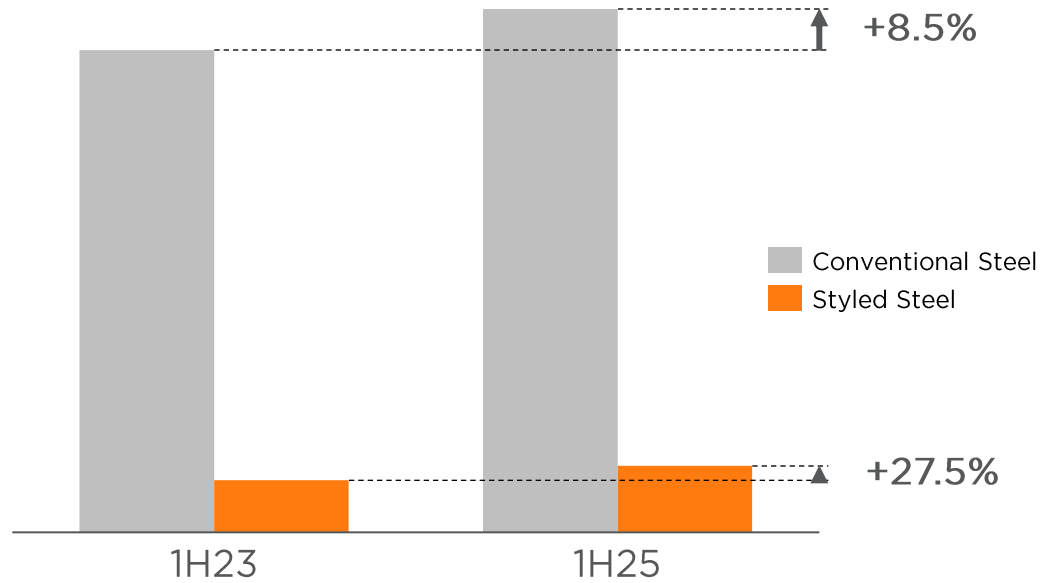

AFFORDABLE VALUE- ADD PRODUCTS: INCREASING SALES WITH NEW TECHNOLOGIES

Maxion FUSION: combining materials and functionality for added value; 2 customer co-development programs in process

NVH Wheel Technology: tuning the steel wheel disc and rim profile to reduce noise; significant additional volume in 2025

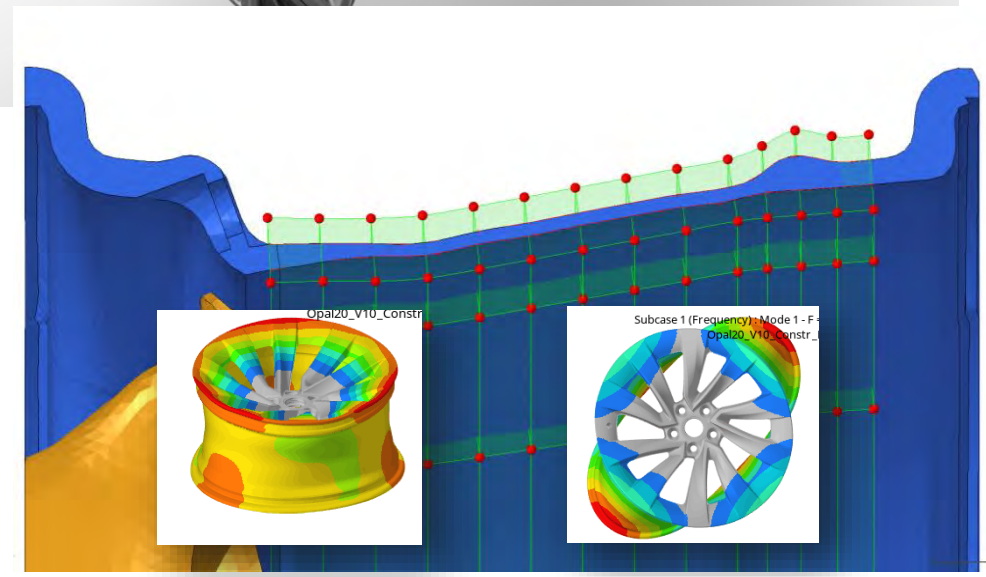

NVH
Wheel Technology



GROWTH ENGINES: NEW APPLICATIONS



NEW APPLICATIONS: GROWTH WITH SPECIALTY WHEELS

Serving various niche applications including agriculture, forklift with sought after wheel expertise

Supplying **defense from a growing number of plants** in the Americas, Europe and Asia

Produced **1.2 million** light trailer and recreational vehicle wheels in 2024, **3x** the output compared to 2019



NEW APPLICATIONS: COMMERCIAL FORGED ALUMINUM WHEELS

New forged aluminum truck wheel line for OEMs and fleets looking for a performance-engineered payload efficiency solution

Start of Production end of 2025

Signed Letters of Intent to sell to several OEMs

Distribution network primed and ready to sell



Unique advanced proprietary surface treatment solution to launch in 2026.



GROWTH ENGINES: NEW CUSTOMERS

NEW CUSTOMERS: LEVERAGING COMPREHENSIVE PORTFOLIO AND EXPERTISE TO EXPAND CUSTOMER BASE

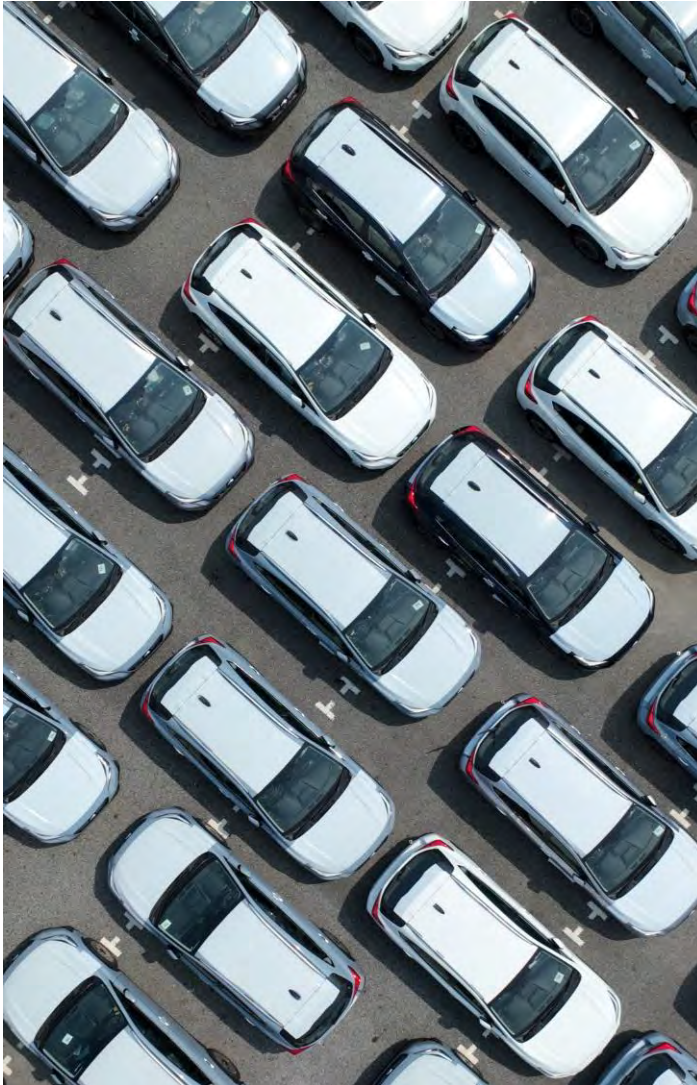

Supplying wheels to more than **100+** different OEM customers: **gained 24 new OEM customers in last 5 years — including Chinese OEMs outside of China**

Chinese OEM production outside China projected to double in next 5 years: Maxion target is well-positioned to **capture relevant share**

Continuously expanding wheel expertise from running hundreds of wheel programs a year: serving as in-house wheel experts for **many new customers**

7% increase in new business wins for 1H25 compared to 1H24

RELENTLESS EXECUTION: FROM AGILE OPERATIONS, GLOBAL STANDARDS AND STRONG DISCIPLINE



Operational Excellence

Diligently improving productivity processes to achieve superior performance

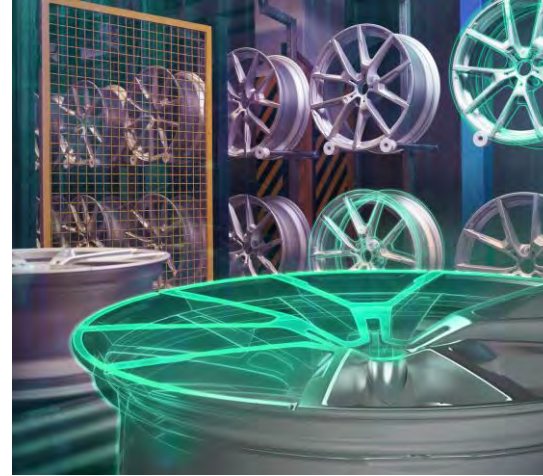

Smart Processes and Tools

Enhancing business performance and attracting top talent by leveraging advanced digital tools and data-driven strategies



Engaged Workforce

Driving profitability with a positive and engaged team

RELENTLESS EXECUTION: OPERATIONAL EXCELLENCE THAT DRIVES PREDICTABLE PERFORMANCE

Global M2S Management System standards, along with action plans and monthly audits, drive productivity performance

More than **2,200** certified belts; **130** Black Belts leaders driving out waste and improving productivity

Continue to apply disciplined capex culture (payback driven) and global purchasing power

More than **450** Natural Work Teams around the world; annual best-practice award event accelerates adoption in other plants; **748** projects judged in 2024

Source: Iochpe-Maxion internal reporting.



RELENTLESS EXECUTION: SMART PROCESSES AND TOOLS TO ACCELERATE EFFICIENCIES

Global implementation of digital tools focused on maintenance, energy, material planning and procurement enhances Maxion's operational flexibility, speed, and efficiency

Consistently recognized by prestigious industry award programs for our focus on and advancement of digitalization initiatives; **30** awards in 2024

The number of digitalization projects is increasing as more opportunities for cost savings are identified



Source: Iochpe-Maxion internal reporting.

RELENTLESS EXECUTION: ENGAGED AND EMPOWERED WORKFORCE READY FOR A DYNAMIC FUTURE

Investing in our competitive advantage with a thriving and engaged workforce; **86%**¹ engagement rate (**9 p.p.**) above high-performance companies

Enabling employees to generate innovative ideas and solutions that drive value creation; **558**² ideas in 2024

Adapting to technological change and addressing workforce skill gaps to future-proof the business

Source: ¹2023 Korn Ferry global employee engagement survey.
²2023 Iochpe-Maxion internal reporting.



A SUCCESSFUL APPROACH

- Adapting to industry changes through flexible operations and relentless execution
- Realizing growth objectives by adding customers, increasing market share and enhancing sales through innovative and higher value-add offerings
- Investing in and empowering talent to drive business success

PIETER KLINKERS
PRESIDENT AND CEO
IOCHPE-MAXION



AFFORDABLE SUSTAINABILITY: A COMPETITIVE EDGE

OUR PEOPLE, OUR PURPOSE: CELEBRATING THE HEART OF MAXION

Leading a skilled, multidimensional workforce of **over 40 nationalities**

Establishing an environment that encourages **engagement and enablement**

Developing talent with a focus on current and future business strategies

Executing We Care to address the importance of our cultural, wellbeing, environmental, and social responsibilities

Source: Iochpe-Maxion internal reporting.



DIVERSITY & INCLUSION
127 Activities in 2024

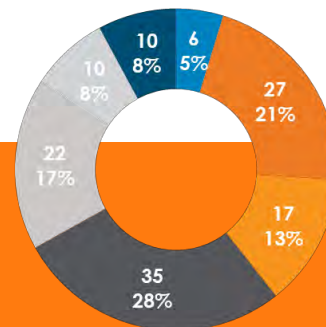

SOCIAL IMPACT
116 Activities in 2024

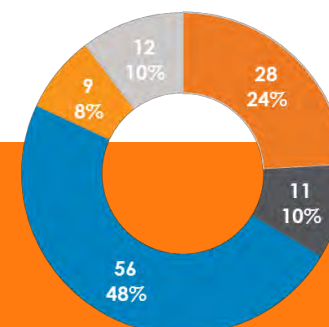

WELLBEING
109 Activities in 2024

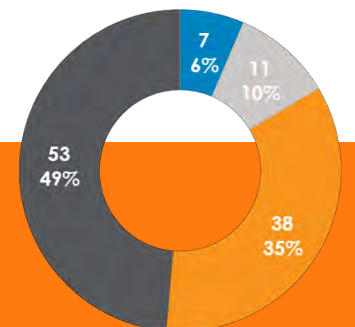

TRANSFORMING LIVES THROUGH EDUCATION: CELEBRATING 35 YEARS OF IOCHPE FOUNDATION

2024 HIGHLIGHTS



1,000+
Youth Served

4,300+
Active Volunteers



63
Units in Brazil,
Mexico and India



45
Partner Companies



CLOSING

- MAXION is in a favorable position given its strong global footprint and agile operations
- Will focus on more with less. Smaller but quick payback projects, more applications, more new products, more AI/Digital Transformation
- Continued drive to grow and strengthen the balance sheet, deliver shareholder value

MARKETS ARE DYNAMIC, MAXION COMMITTED TO PERFORM

CLOSING

“You cannot overtake
15 cars in sunny
weather...but you can
when it's raining

Ayrton Senna



Q & A

APIMEC



MAXION